

THIS DRAWING IS UNPUBLISHED. RELEASED FOR PUBLICATION, 19 .
© COPYRIGHT 19 BY AMP INCORPORATED. ALL INTERNATIONAL RIGHTS RESERVED.

LOC	DIST	P	F	REVISIONS				
AF	50			ZONE	LTR	DESCRIPTION	DATE	APPD
					D	REV PER 0710-0162-96	4/24/96	JR/JG

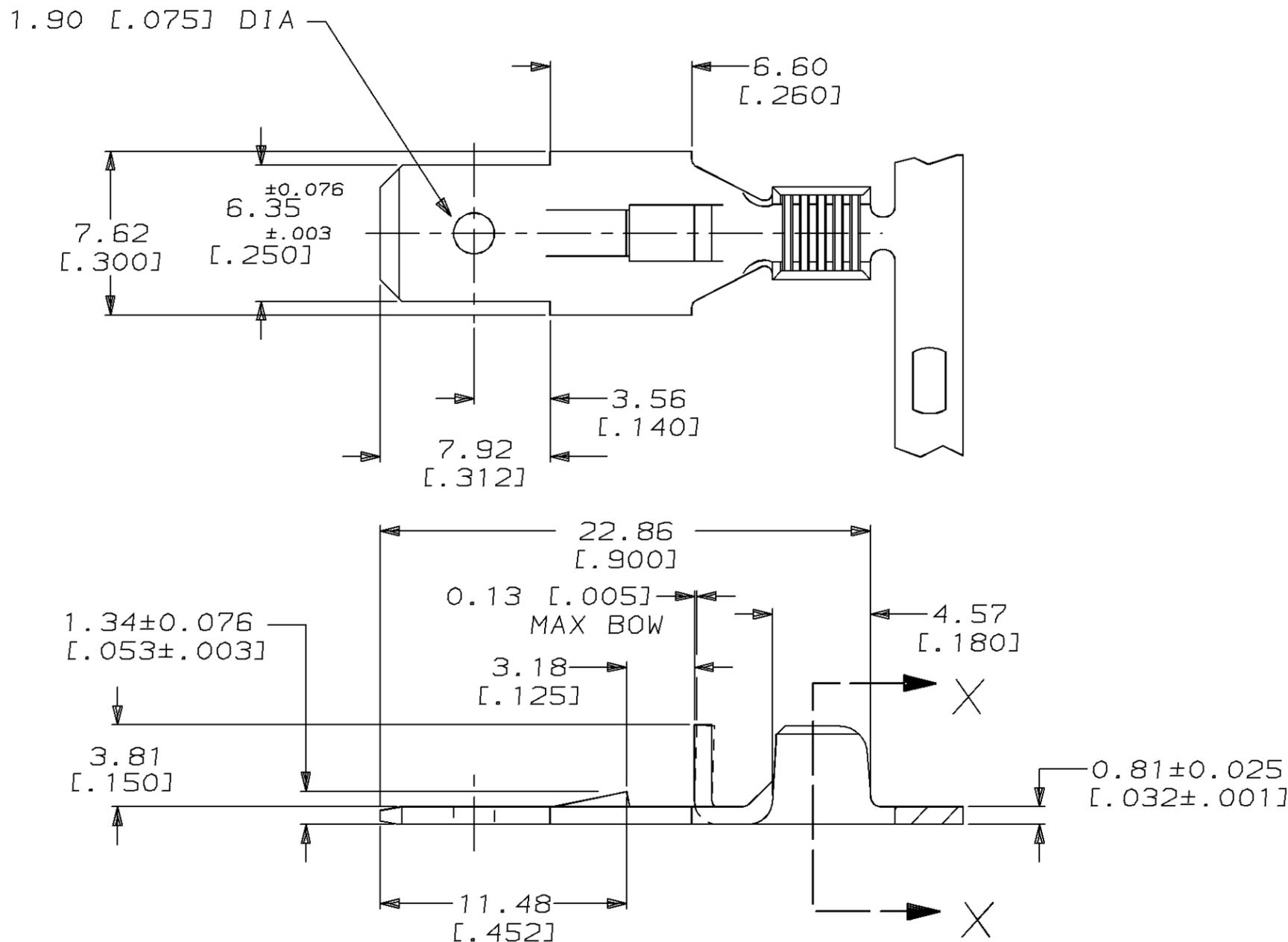

- 1 CONTINUOUS STRIP ON REELS.
- 2 0.002032 [0.000080] MIN TIN PLATE, ALL OVER.

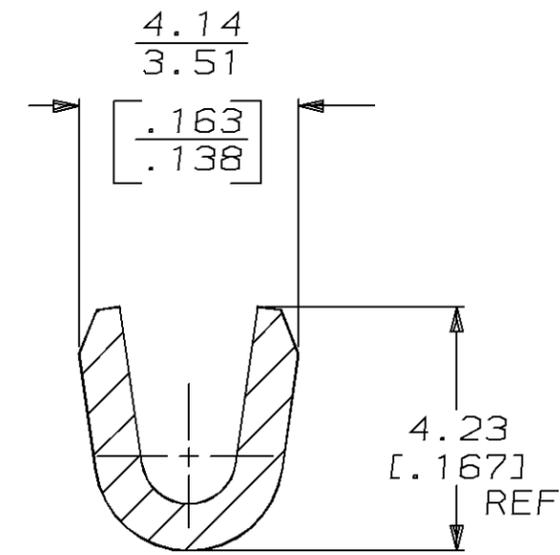

SECTION X-X
SCALE 8:1

THIS DRAWING IS A CONTROLLED DOCUMENT FOR AMP INCORPORATED. IT IS SUBJECT TO CHANGE AND THE CONTROLLING ENGINEERING ORGANIZATION SHOULD BE CONTACTED FOR THE LATEST REVISION.

DO NOT SCALE PRINT. UNLESS SPECIFIED DIMENSIONS IN mm [INCHES] TOLERANCES ON: 2 PLC DEC ± 0.25 [0.010] 3 PLC DEC ± - ANGLES ± -	DR 5/23/95 JR RUTH CHK 5/23/95 MS FEHER APPD 5/23/95 J GILLESPIE APPD 5/23/95 R REINER PRODUCT SPEC -
MATERIAL 082 BRASS	FINISH 2
APPLICATION SPEC 114-2070	
WEIGHT -	

1010-4100 CMA	63858-1
WIRE SIZE	PART NO
AMP AMP Incorporated Harrisburg, PA 17105-3608	
NAME TAB, FASTON, AMPLIVAR, 6.35 [0.250] SERIES	
SIZE B	CAGE CODE 00779
SCALE 4:1	DRAWING NO C-63858
SHEET 1 OF 1	